

E-502 type, replacement product of John Crane 502 type, Rubber bellows type mechanical seal

Temperature: -40~+205°C

Speed: 13m/s

Pressure: 2.5Mpa

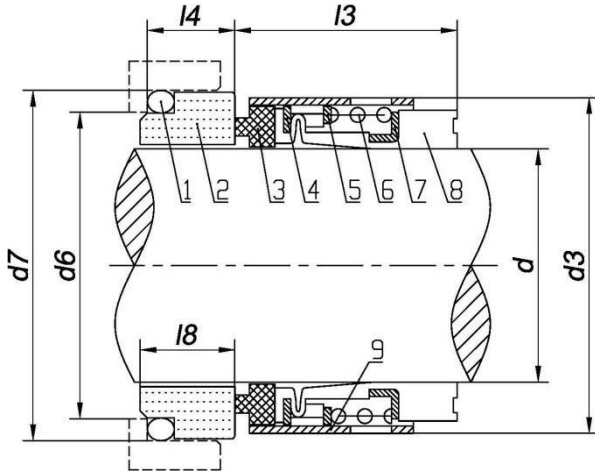

- 1 O-ring
- 2 Stationary ring
- 3 Rotary ring
- 4 Washer
- 5 Washer
- 6 Spring
- 7 Drive collar
- 8 Bellows
- 9 Outer sleeve

d	d3	d6	d7	l3	l4	l8
14	24	21	25	23	12	12.8
16	26	23	27	23	12	12.8
18	32	27	33	24	13.5	14.5
20	34	29	35	24	13.5	14.5
22	36	31	37	24	13.5	14.5
24	38	33	39	26.7	13.3	14.3
25	39	34	40	27	13	14
28	42	37	43	30	12.5	13.5
30	44	39	45	30.5	12	13
32	46	42	48	30.5	12	13
33	47	42	48	30.5	12	13
35	49	44	50	30.5	12	13
38	54	49	56	32	13	14
40	56	51	58	32	13	14
43	59	54	61	32	13	14
45	61	56	63	32	13	14
48	64	59	66	32	13	14
50	66	62	70	34	13.5	14.5
53	69	65	73	34	13.5	14.5
55	71	67	75	34	13.5	14.5
58	78	70	78	39	13.5	14.2
60	80	72	80	39	13.5	14.2
63	83	75	83	39	13.5	14.2
65	85	77	85	39	13.5	14.2
68	88	81	90	39	13.5	14.2
70	89	83	92	45.5	14.5	15.2
75	96	88	97	45.5	14.5	15.2
80	104	95	105	45	15	15.7
85	108	100	110	45	15	15.7
90	114	105	115	50	15	15.7
95	118	110	120	50	15	15.7
100	124	115	125	50	15	15.7