

# DEPESEAL MECHANICAL SEAL DEPESEAL mechanical sealing

E-WB2 type, replacement product of John Crane WB2 type, PTFE bellows type mechanical seal

Temperature: +45~+120°C

Speed: 16m/s

Pressure: 1.3Mpa

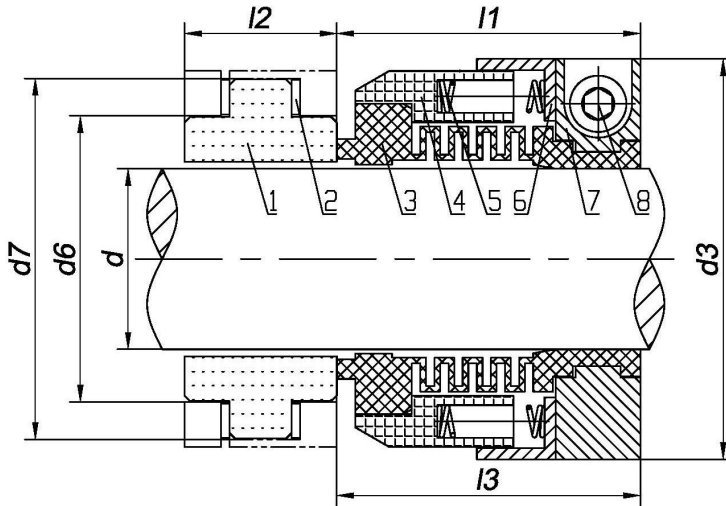

- 1 Stationary ring
- 2 Washer
- 3 Rotary ring
- 4 Rotary seat
- 5 Spring
- 6 Cover
- 7 Split clamp
- 8 HSH cap screw

<i>d</i> (inch)	<i>d</i> 3	<i>d</i> 6	<i>d</i> 7	<i>l</i> 1	<i>l</i> 3	<i>l</i> 2
25.4	60	42.86	54	42	45	17.5
28.6	67	46.03	60	42	45	27
31.75	69	50.8	65	42	45	27
34.93	72	53.98	68	42	45	27
38.1	76	57.15	71	42	45	27
41.28	80	63.5	78	42	45	27
44.45	84	66.68	81	44	46	27
47.63	86	69.85	84	44	46	27
50.8	90	73.03	87	46	46	27
53.98	95	73.98	97	46	46	33.5
57.15	98	82.55	100	46	46	33.5
60.3	100	85.73	103	46	46	33.5

<i>d</i>	<i>d</i> 3	<i>d</i> 6	<i>d</i> 7	<i>l</i> 1	<i>l</i> 3	<i>l</i> 2
25	60	47	60	42	45	27
30	67	53	67	42	45	27
32	69	50.7	64	42	45	27
35	72	57	70	42	45	27
40	78	62	76	42	45	26
45	84	67	82	44	46	27
50	88	72	86	46	46	27
55	95	77	90	46	46	27
60	100	82	95	46	46	27
65	105	87	100	46	46	27