

DEPESEAL MECHANICAL SEAL **DEPESEAL mechanical sealing**

E-5BU type, replacement product of John Crane 5BU type, Rubber bellows type mechanical seal

Temperature: -40~+230°C

Speed: 25m/s

Pressure: 1.7Mpa

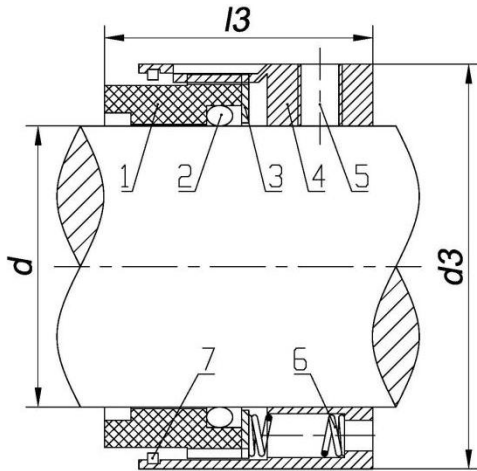

- 1 Rotary ring
- 2 O-ring
- 3 Washer
- 4 Transmission sleeve
- 5 Set screw
- 6 Spring
- 7 Snap ring

d	d3	l3
14	24	23
16	26	23
18	32	24
20	34	24
22	36	24
24	38	26.7
25	39	27
28	42	30
30	44	30.5
32	46	30.5
33	47	30.5
35	49	30.5
38	54	32
40	56	32
43	59	32
45	61	32
48	64	32
50	66	34
53	69	34
55	71	34
58	78	39
60	80	39
63	83	39
65	85	39
68	88	39
70	90	45
75	95	45
80	104	45
85	109	45
90	114	50
95	119	50
100	124	50