

DEPESEAL MECHANICAL SEAL **DEPESEAL mechanical sealing**

E-8-1 type, replacement product of John Crane 8-1 type, Rubber bellows type mechanical seal

Temperature: -20~+180°C

Speed: 15m/s

Pressure: 1.2Mpa

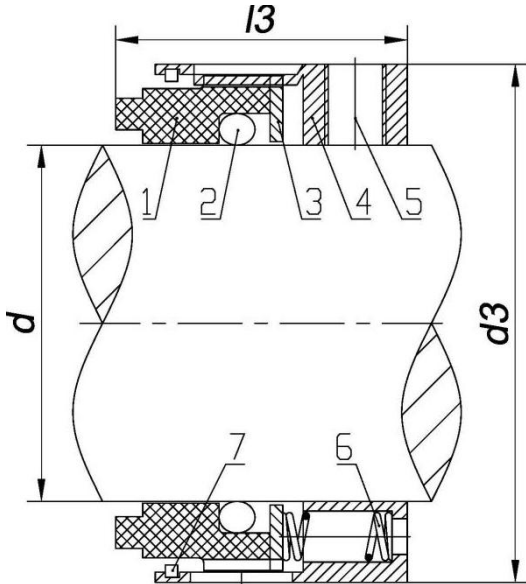

- 1 Rotary ring
- 2 O-ring
- 3 Washer
- 4 Transmission sleeve
- 5 Set screw
- 6 Spring
- 7 Snap ring

d(inch)	d	d3	l3
0.5	12.7	26.19	20.62
0.625	15.8	30.15	19.05
0.75	19.1	33.32	22.23
0.875	22.2	36.5	23.8
1	25.4	39.67	25.4
1.125	28.6	42.85	26.97
1.25	31.7	47.63	26.97
1.375	34.9	50.8	28.58
1.5	38.1	53.98	28.58
1.625	41.2	60.33	34.93
1.75	44.4	63.5	34.93
1.875	47.6	66.68	34.93
2	50.8	69.85	34.93
2.125	53.9	76.2	42.85
2.25	57.1	79.38	42.85
2.375	60.3	82.55	42.85
2.5	63.5	85.73	42.85
2.625	66.6	88.9	42.85
2.75	69.8	92.08	42.85
2.875	73	95.25	42.85
3	76.2	96.82	42.85
3.125	79.3	100	42.85
3.25	82.5	104.78	42.85
3.375	85.7	107.95	42.85
3.5	88.9	111.13	42.85
3.625	92	114.3	42.85
3.75	95.2	117.48	42.85
3.875	98.4	120.65	42.85
4	101.6	123.83	42.85